

## CTi-1000/CTi-1001 integrated turbo compressor system

Highly compact, high-speed, electrically driven radial turbo compressor with gas bearing and integrated converter for the circulation and compression of various gases and refrigerants.

- High-speed gas bearings for oil free operation
- Aerodynamic and electromagnetic optimization for highest total efficiency, lowest ratio of volume and weight versus pressure and mass flow due to highest speeds
- Auxiliary voltage supply (8 – 32 VDC) for startup of the turbo compressor from battery, automatic switch to fuel cell voltage
- Operation of the turbo compressor from wide output voltage range of the fuel cell or battery (40 – 120 VDC)



Specifications turbo compressor system		
Model	CTi-1000	CTi-1001
Maximum pressure ratio	1.65	1.65
Maximum mass flow	15 g/s	21 g/s
Maximum isentropic overall efficiency <sup>1</sup>	55%	59%
Maximum speed	280,000 rpm	280,000 rpm
Acceleration time <sup>2</sup>	< 1.0 s	< 1.0 s
Maximum converter input power	1 kW	1.2 kW
Nominal high voltage input $U_{HV}$ <sup>3</sup>	40 – 120 VDC	
Low voltage power input $U_{LV}$ (Auxiliary supply)	8 – 32 VDC	
Maximum output power and speed for start-up (low voltage operation)	50 W/115 krpm	50 W/105 krpm
Communication interface	CAN 2.0A, CAN 2.0B, RS232-USB (Service Interface)	
Air inlet temperature range	-20 – 55 °C	
Mechanical mounting	4 x M4 x 6	
Dimensions (L x W x H)	182.6 x 90 x 93.7 mm (7.18 x 3.54 x 3.68 inch)	
Weight	2 kg	

Low voltage/High voltage input	
3 x CAN interface	CanH, CanL, CanGND
2 x Serial interface (Service Interface)	TX, RX
2 x Low voltage input $U_{LV}$	1 x LV+, 1 x LV-
6 x High voltage input $U_{HV}$	3 x HV+, 3 x HV-
1 x PE	Protective earth
Connector type	TE Connectivity/AMPSEAL 14 Pos.

<sup>1</sup> Isentropic overall system efficiency including aerodynamic, motor, bearing and converter efficiency

<sup>2</sup> 20 to 80% of maximum speed

<sup>3</sup> At extreme supply voltage conditions and depending on the compressor system operating conditions (input voltage, inlet temperature, cooling fluid temperature...), a de-rating may become active for the self-protection of the device.

All rights reserved. All information in this document is based on Celeroton TurboCell's best knowledge and is not to be considered as a warranty or quality specification. The information given is designed as a guidance and customers are requested to check the suitability and usability of the product in their specific application with consulting Celeroton TurboCell. The information herein is subject to change without notification.

### Cooling

Liquid	Inhibited 50%/50% water glycol mixture
Coolant temperature	-20 – 65 °C
In-/outlet connector thread	G 1/8"

### Converter grounding

Grounding thread	M4 x 6 (identical to mechanical mounting)
------------------	---

### Compressor map: overpressure operation - CTi-1000

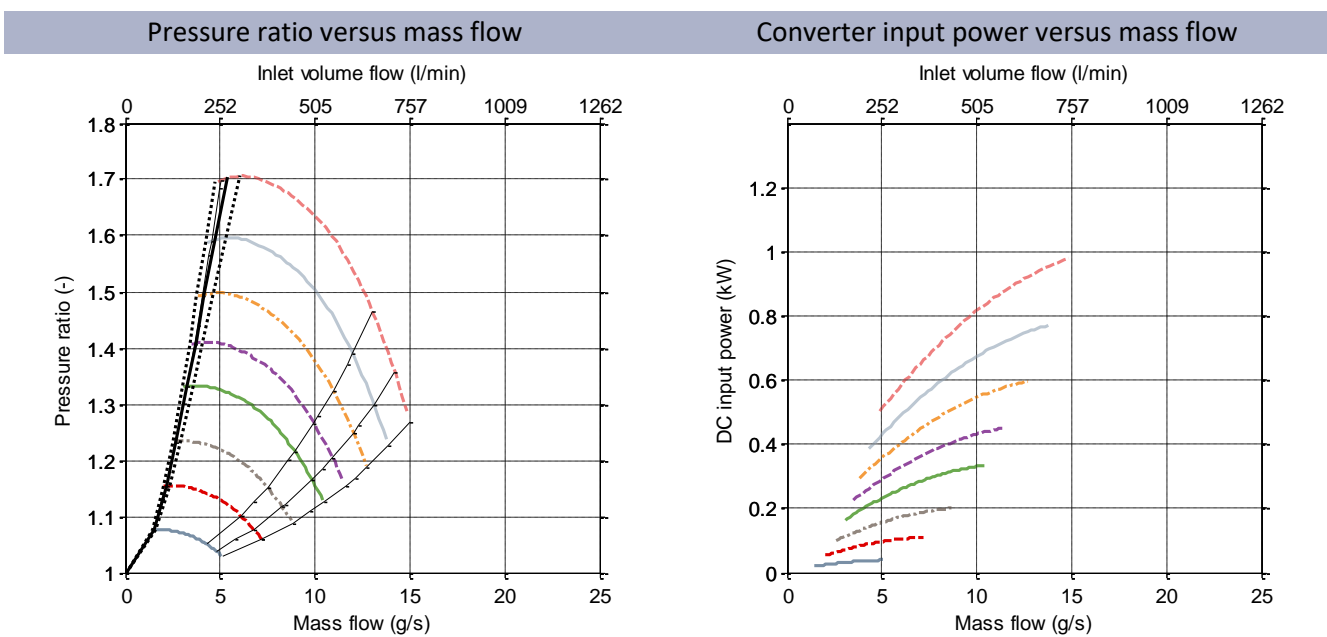

### Compressor map: overpressure operation - CTi-1001

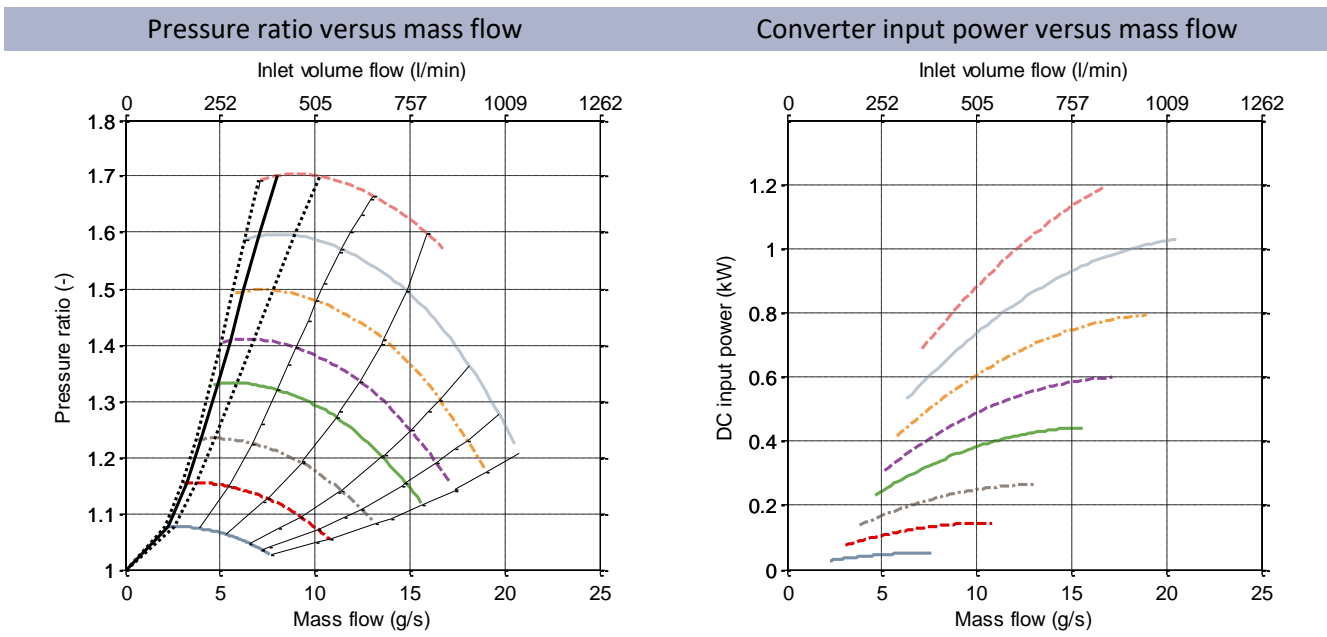

All rights reserved. All information in this document is based on Celeroton TurboCell's best knowledge and is not to be considered as a warranty or quality specification. The information given is designed as a guidance and customers are requested to check the suitability and usability of the product in their specific application with consulting Celeroton TurboCell. The information herein is subject to change without notification.

Order codes: CTi-100X

Ordering information	Article number
CTi-1000 - Integrated turbo compressor system	contact sales
CTi-1001 - Integrated turbo compressor system	contact sales
Supply cable CTi-1000/CTi-1001	contact sales
Low and high voltage supply cable with CAN 1 m (open ends)	
Service cable CTi-1000/CTi-1001	contact sales
Low and high voltage supply cable with CAN and USB 1 m (open ends)	

**Drawing in mm [inch]**

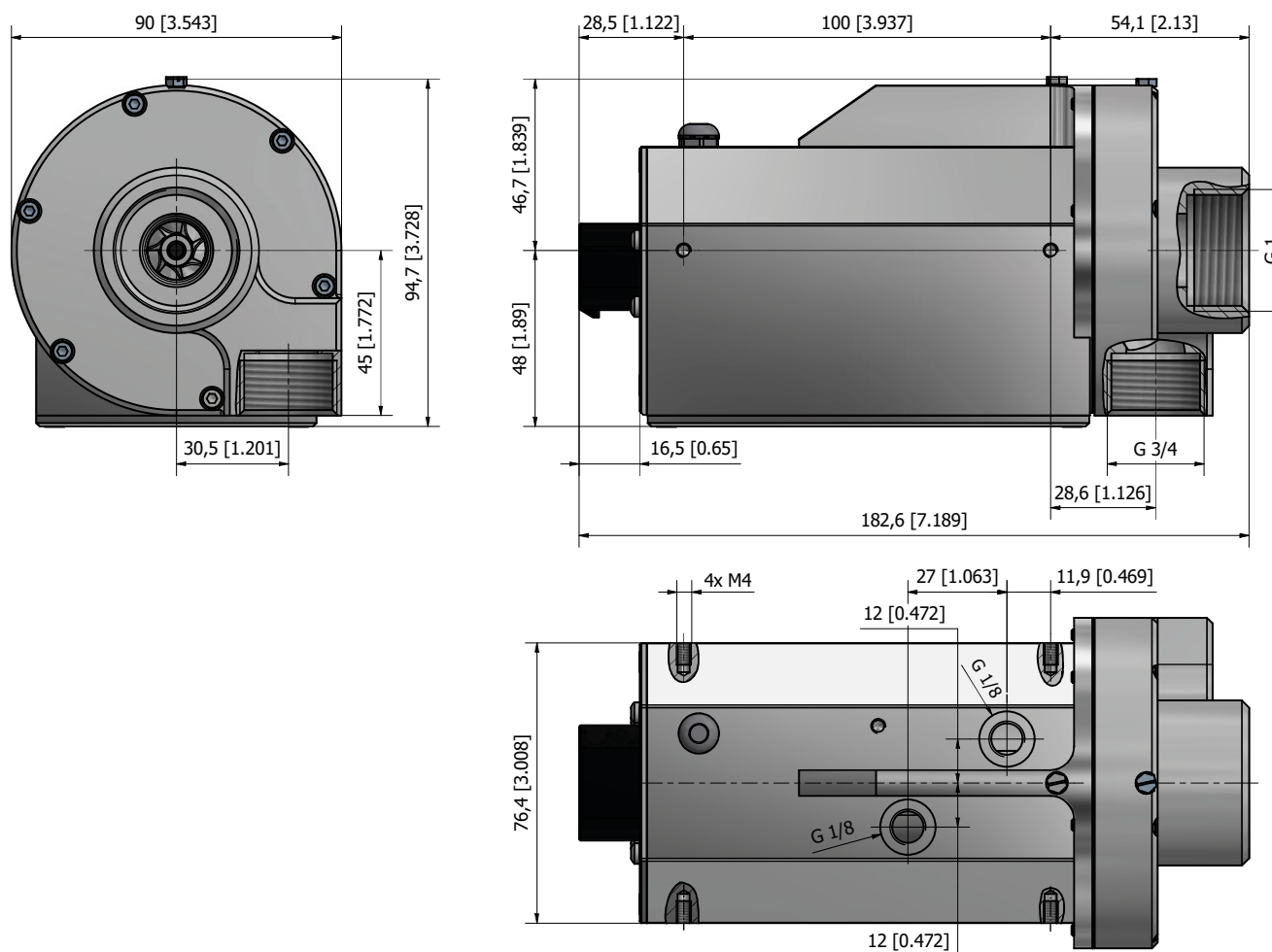

All rights reserved. All information in this document is based on Celeroton TurboCell's best knowledge and is not to be considered as a warranty or quality specification. The information given is designed as a guidance and customers are requested to check the suitability and usability of the product in their specific application with consulting Celeroton TurboCell. The information herein is subject to change without notification.



The specifications and compressor maps in this document refer to air (ISO 8778) at the inlet of the compressor: temperature:  $T = 20^{\circ}\text{C}$ , absolute pressure:  $p_{in} = 1 \text{ bar}$ .



Depending on custom specific operation conditions such as e.g. gas inlet pressure and temperature, humidity, cooling conditions, the operation in environmental conditions with vibrations, the compressor maps shown in this document may be different or may have additional limitations.

For technical details and further information, please refer to the user manual or contact Celeroton TurboCell directly.